



Powerful, Easy Versatile Drive **N750E**



N750E

Versatile Compact Drive N750E

N750E's compact size and sensorless vector control technology provide optimized performance for industrial equipment.

Easy Maintenance

Removable Keypad

Soft Simple Control

Reliable Power module

Flexible I/O Interface





Product Range

- 1 Phase 220V 0.4kW ~ 2.2kW
- 3Phase 220V 0.4kW ~ 15kW
- 3Phase 440V 0.4kW ~ 22kW

Excellent Applicability

- KEB Function
- External Brake Control (for Lift, Hoist)
- Automatic current suppression function (Minimization of inverter stop)
- Adoption of optimal algorithm to minimize the motor loss

High Performance

- V/F, User V/F, Enhanced Sensorless Vector control
- Dual Rating (Heavy Duty & Normal Duty)
- High Torque at low speed (150% @ 1 Hz)
- Built-in EMC Filter (Optional, Above 5.5kW~)

Easy, Simple, User friendly Options

- Removable Keypad
- Side by Side Installation
- Built-in Fieldbus communication (Optional)
- Easy Installation & Simple Operation

■ Specifications

Applied Motor		1Phase 220V (200~240V, ±10%, 50/60Hz)			3Phase 220V (200~240V, ±10%, 50/60Hz)			3Phase 440V (380~480V, ±10%, 50/60Hz)		
kw	hp	Frame	Model	A	Frame	Model	A	Frame	Model	A
0.4	0.5	N1	C1-004SF	2.8 (3.2)	N1	C1-004LF	2.8 (3.2)	N2	C1-004HF	1.5 (1.8)
0.75	1	N1	C1-007SF	4.8 (5.0)	N1	C1-007LF	4.8 (5.0)	N2	C1-007HF	2.7 (3.4)
1.5	2	N2	C1-015SF	7.5 (8.5)	N1	C1-015LF	7.5 (8.5)	N2	C1-015HF	4.2 (4.8)
2.2	3	N2	C1-022SF	11.0 (12.5)	N2	C1-022LF	11.0 (12.5)	N2	C1-022HF	5.5 (7.2)
3.7	5				N3	C1-037LF	17.0 (19.5)	N3	C1-037HF	9.0 (10.5)
5.5	7.5				N4	C1-055LF	25 (30)	N4	C1-055HF	14.8 (17.5)
7.5	10				N4	C1-075LF	33 (40)	N4	C1-075HF	18 (23)
11	15				N5	C1-110LF	47 (56)	N5	C1-110HF	24 (31)
15	20				N6	C1-150LF	64 (73)	N5	C1-150HF	32 (38)
18.5	25							N6	C1-185HF	39 (44)
22	30							N6	C1-220HF	45 (58)

■ Dimension

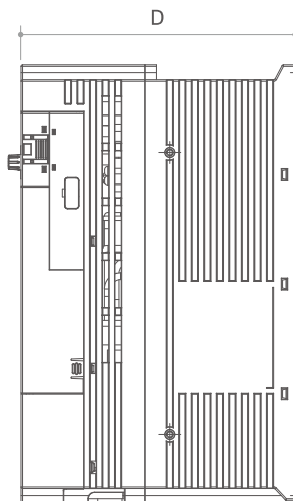
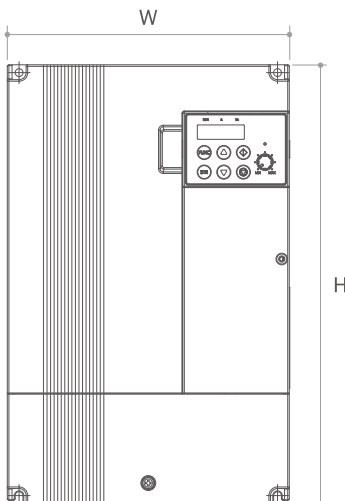
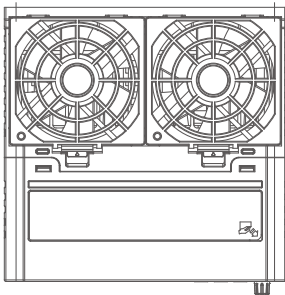

Frame	N1	N2	N3
W [mm]	68	108	140
H [mm]	128	128	128
D [mm]	149	159	164
Weight [kg]	0.8	1.0	1.3

Frame	N4	N5	N6
W [mm]	160	180	220
H [mm]	230	280	315
D [mm]	175	175	185
Weight [kg]	4.5	7.0	8.0

■ Controls

Item	Specification
Control Mode	V/F Control, User V/F, Enhanced sensorless vector control
Frequency Setting Range	0.01 to 400Hz
Frequency Tolerance	Digital Reference : $\pm 0.01\%$ Analog Reference : $\pm 0.1\%$
Frequency Setting Resolution	Digital Command : 0.01 Hz Analog Command : 0.03 Hz / 60 Hz
Output Frequency Resolution	0.01 Hz
Frequency Setting	0~10 [V], 4~20 [mA], Keypad
Carrier Frequency	1~10kHz (default ND : 3kHz, HD : 5kHz)
ACC/DEC Time	0.1~3000sec (linear , S curve, U curve)
Starting Torque	100% / 3 Hz (V/f) 200% / 1 Hz (SLV)

Item		Specification
Protective Function	Overcurrent	Exceeds internal over current trip level
	Overload	150%(HD) , 120%(ND) 60s
	Overvoltage	200V Class:410 V / 400V Class:820 V
	Low voltage	200V Class:190 V / 400V Class:380 V
	Heat sink overheat	NTC on IGBT
	Stall Prevention	Stall prevention during acceleration
	Ground Fault	Protection by electric circuit
Environment	Area of Use	Indoor
	Ambient Temperature	HD : -10 to 50°C / ND : -10 to 40°C
	Humidity	95% RH or less (no condensation)
	Storage Temperature	-20 to 60°C
	Altitude	Up to 1000 m
	Vibration	10Hz~20Hz 1G, 20Hz~55Hz 0.6G
Standard		UL 508C, EN61800-3 C3(2004/108/EC) EN61800-5-2, IEC6158:SIL 3
Protective Design		Open IP20

■ Diagram

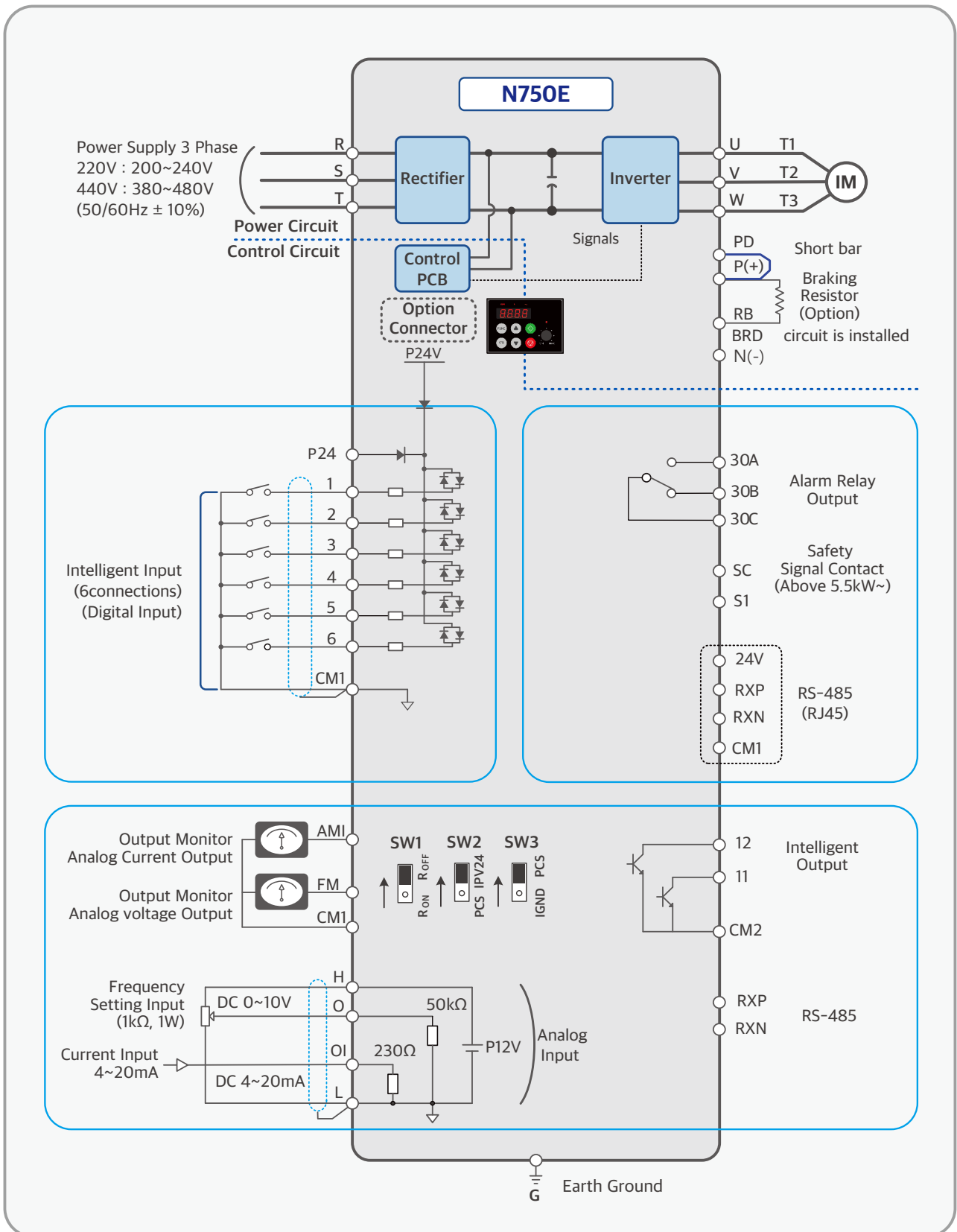

Control Circuit Terminal

Control Circuit Terminal

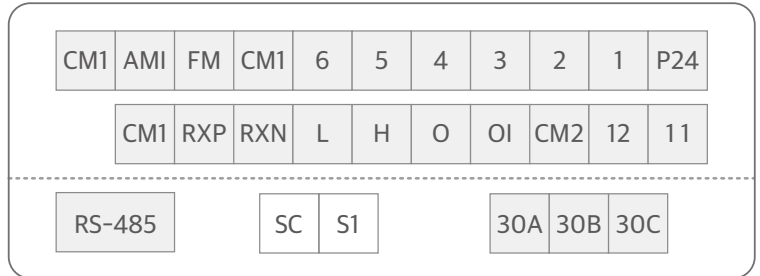

Terminal Symbols	Terminal Name	Specification	Remark
1~6	Intelligent Input Terminal	Min. on time: 12ms	
P24	Intelligent Input Terminal Power	24VDC±15%, 100mA	Refer to Diagram
CM1	Common Terminal for Input	-	
11, 12	Intelligent Output Terminal (O,C)	24VDC, 50mA MAX	Relay Output Changeable
CM2	Common Terminal for Output	-	(Conversion Board-Optional)
30A, 30B, 30C	Alarm Relay Output Terminal	30A(NO),30B(NC),30C(Comm.)	Refer to Diagram
H, O, OI, L	Frequency Command Terminal (V,A)	H(+10V), O(0~10V), OI(4~20mA), L(-)	
FM, AMI, L	Analog Monitor Terminal	FM(0~10V), AMI(4~20mA), L(-)	FM (Output Frequency) AM (Output Current)
RJ45, RXP, RXN	RS-485 Communication Terminal	No. 1 Channel (RJ 45) No. 2 Channel (RXP, RXN)	
S1, SC	Safety Signal Input Terminal	S1(Contact Input), SC(Comm.)	Above 5.5kW ~

Main Circuit Terminal

Main Circuit Terminal

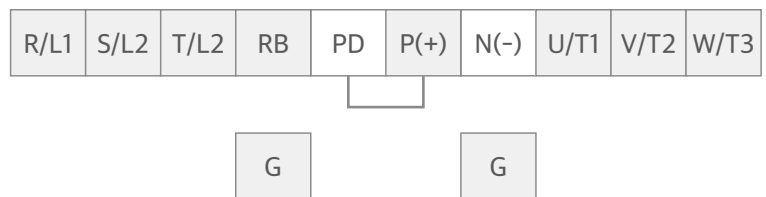

Terminal Symbols	Terminal Name	Function
R,S,T	Main Power Terminal	Connect input power
U,V,W	Inverter Output Terminal	Connect 3Phase motor
PD,P	DC Reactor Connection Terminal	Remove the short bar between PD and P and Connect DC Reactor (Above 5.5kW~)
P, RB	External Braking Resistor Connection Terminal	Connect Braking Resistor (Option)
P, N	External Braking Unit Connection Terminal	Connect Braking Unit (Option, Above 5.5kW~)
G	Earth Ground	Ground the inverter for prevention of electric shock

■ Strong torque performance

Stronger than or equal to competitors in terms of strong low-speed torque performance, high torque performance in all areas.

Previous model

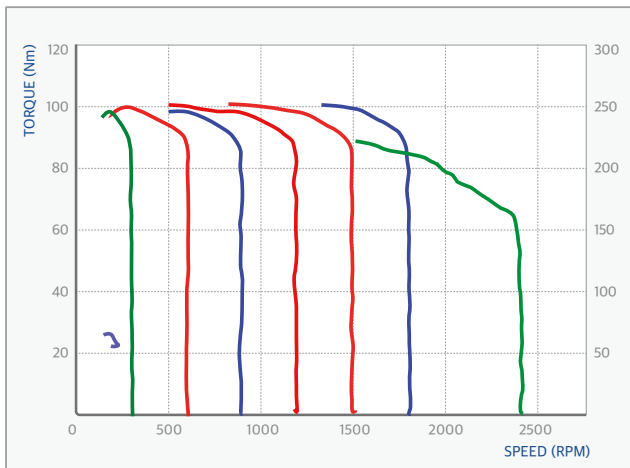

iMaster C1

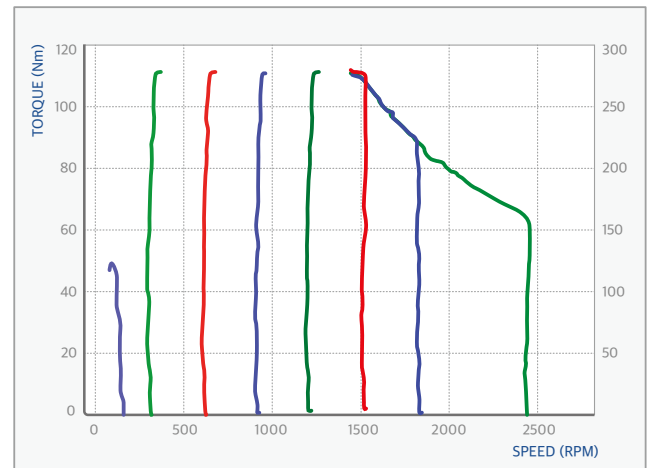

■ Overvoltage Limit Performance (regeneration avoidance)

In the case of regular occurrence of regeneration load, it is possible to increase the output frequency of motor in regeneration zone and control DC link voltage rise.

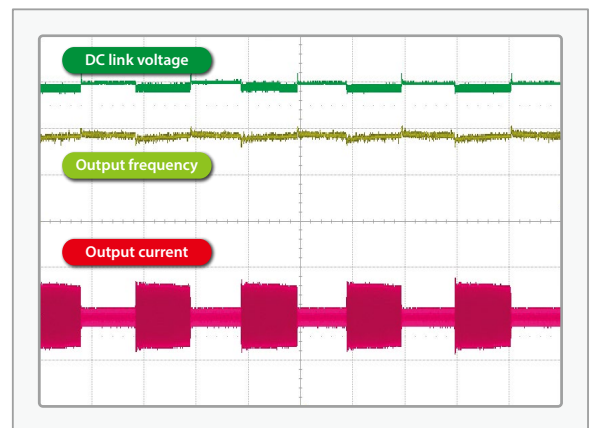

■ Overcurrent Limit Performance

Even in the case of step load, it is possible to control output current smoothly and keep output frequency constantly.

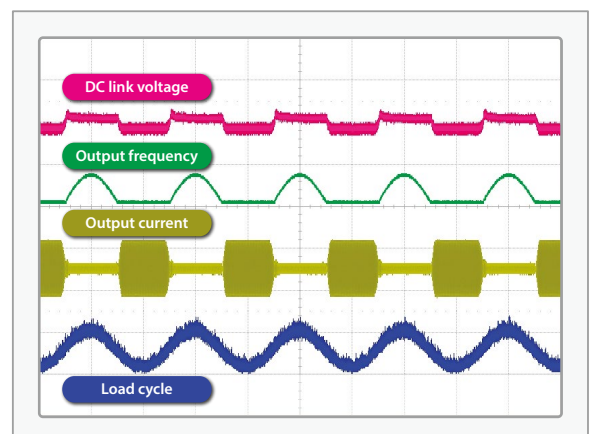

External Brake Control Function (for Lift)

When using external brakes, such as the lift system, it provides safe and elaborated control for all variables, and the operation speed can be changed depending on the load.

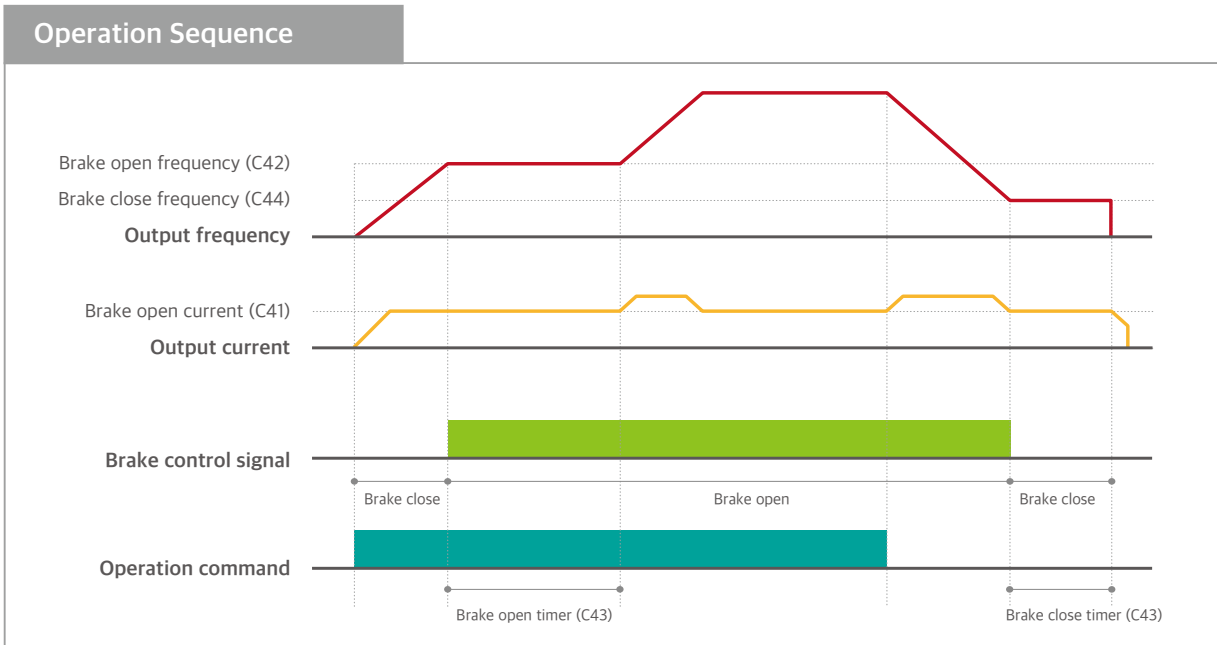

KEB (Kinetic Energy Buffering) function

The KEB function maintains the DC voltage by control the inverter speed during the power failure period, thereby helping maintain the interval between the instantaneous outage and the low voltage trip for a longer time.

The KEB function helps to keep user's facilities safe from any power failure situation.

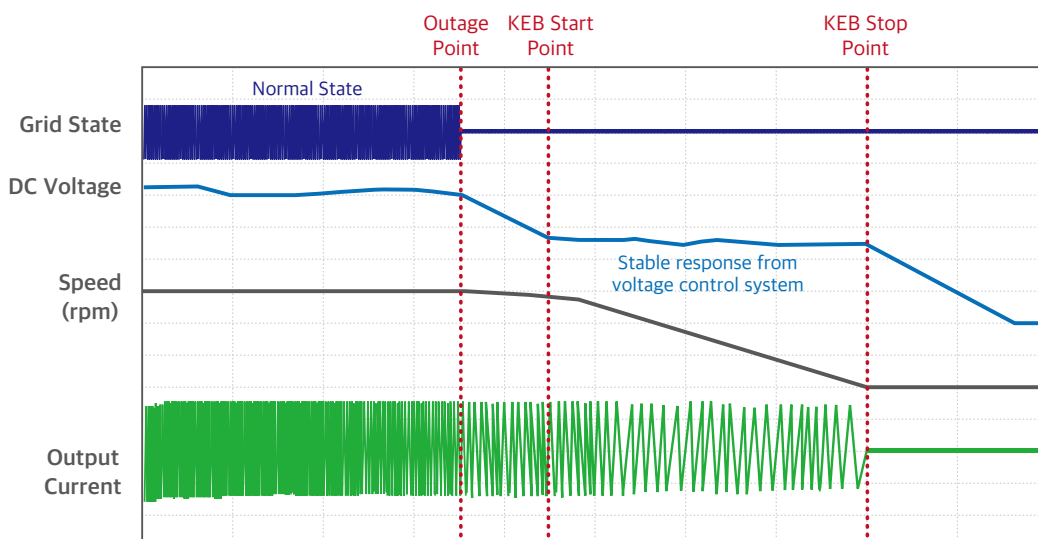

■ RS-485 Communication (2 Channel)

Two channels of Modbus RS-485 communications provide two-way multiple access and multiple inverters integrated operation and monitoring with minimal control wiring and cost savings.

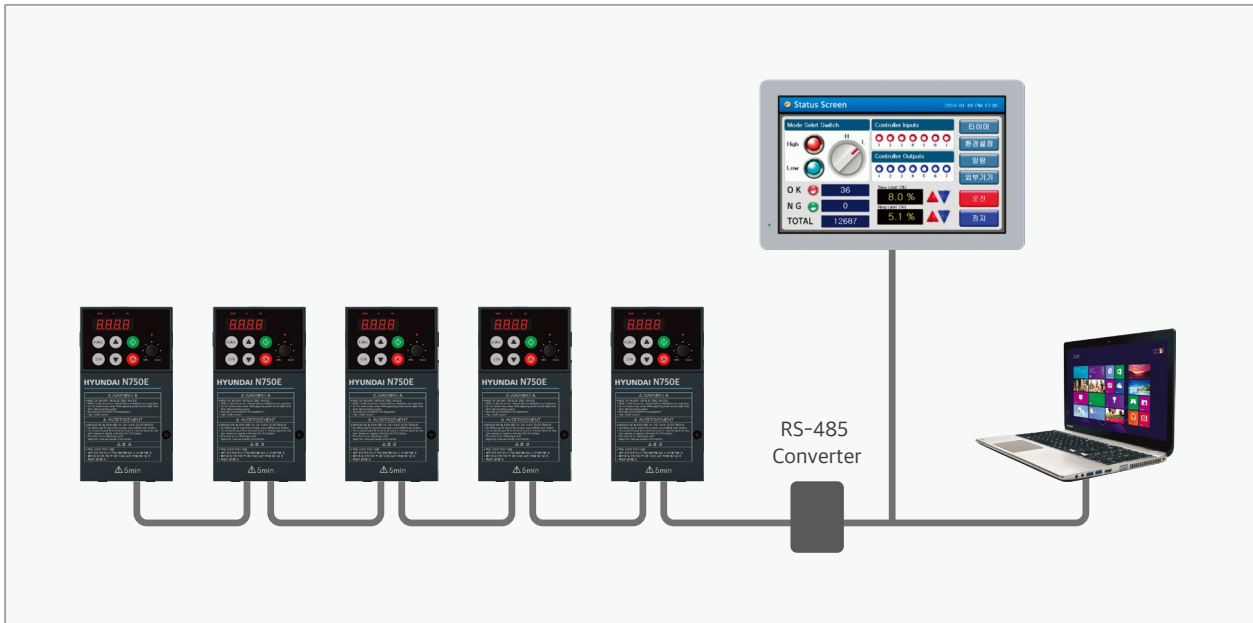

■ Extended Cooling Fan Life

The cooling fan on/off function allows more efficient use of the cooling fan. This feature helps you take longer cooling fan replacement cycles than before.



■ User V/F

User can randomly set the required V/F ratio according to the motor.

User can use following parameters to obtain a suitable V/F pattern for a special motor.

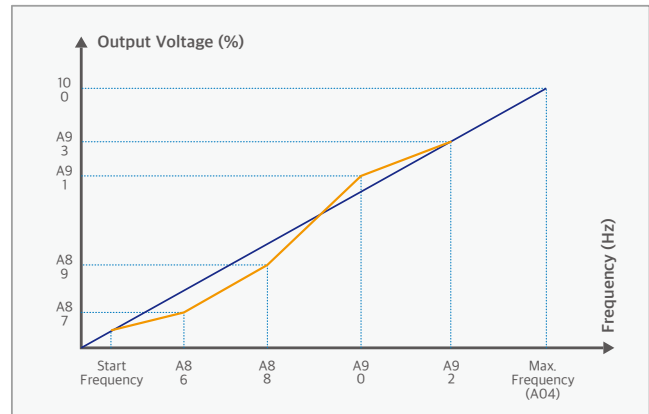

■ Droop Control

To drive the same load, the product responds to the torque change in each of multiple motors to control a speed and to enable each motor to keep an even load.

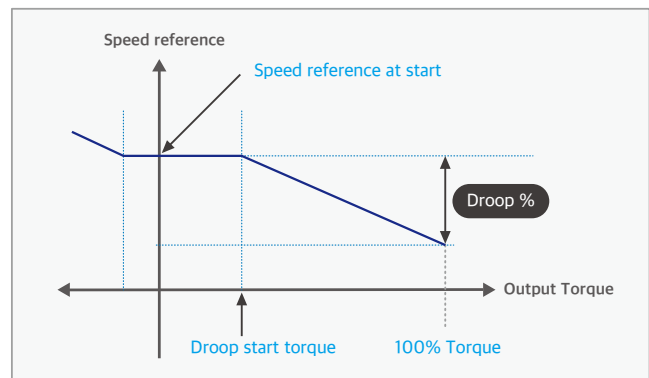

[Load balancing by droop control]

Application

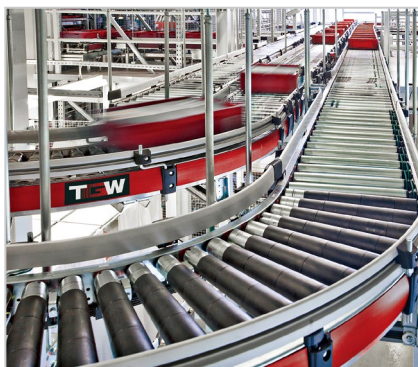



www.adtech21.com

ADT Co., LTD
Headoffice/Factory

#56, Beolmal-ro, Dongan-gu, Anyang-si, Gyeonggi-do, 14059 KOREA

Tel: +82-31-459-5051

Fax: +82-31-459-5053

email: service@adtech21.com